



INSTALLATION INSTRUCTIONS – *Evolution Wastegate*

IMPORTANT: Read instructions completely before proceeding. Engine or turbocharger damage may occur if any wastegate is improperly applied or installed. Consult a knowledgeable turbo installer or Turbonetics tech support specialist with any questions about correct wastegate application or installation.

SUMMARY: Turbonetics' *Evolution Wastegate* has been specifically designed to advance the “state of the art” in modern wastegate design. Properly applied and installed, it can reliably control turbocharger boost pressure in high-performance, single turbo applications up to 400 horsepower, and dual turbo applications to approximately 700 horsepower. Design features include:

- Investment cast stainless steel housing
- “Floating” valve seat, which also serves as the inlet seal
- 1.38” (35mm) diameter valve, made from a special “corrosion & galling resistant” stainless steel
- Fabric-reinforced “rolling” diaphragm
- “Shim” type spring preload adjustment
- Polished & painted actuator cover

The *Evolution Wastegate* has also been specifically designed to directly replace the Deltagate wastegate, offering the benefits of reduced size, lighter weight, increased flow and better control.

OPERATION: The *Evolution Wastegate* controls turbocharger boost by bypassing the turbine inlet gas flow in response to the actuator spring load and/or boost level control signal. The actuator section is fitted with sensing ports on both sides of the diaphragm, allowing precise control of valve motion, and use of any optional external variable boost controller, manual or electronic. A choice of actuator springs is included, to suit specific application requirements.

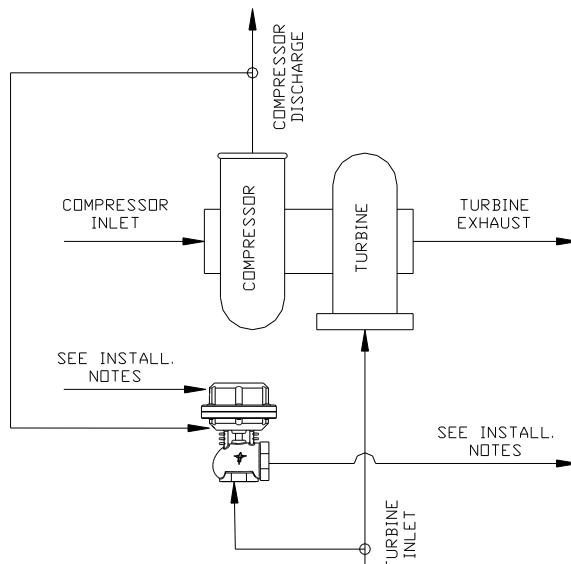

Figure 1:

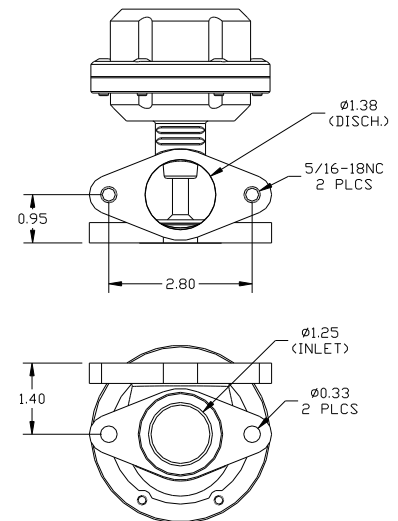

Figure 2:

INSTALLATION: Remove the wastegate from its carton and inspect for any obvious physical damage. All wastegates are thoroughly inspected prior to shipment from the factory. If any shipping damage is evident, contact your supplier and request that they process a claim with the shipper involved.

1. The **Evolution Wastegate** may be located anywhere between the engine exhaust and the turbine inlet of the turbocharger (refer to Figure 1), preferably near the header collector, just before the turbine housing. The wastegate may be mounted in any orientation that is convenient, either directly on a cast exhaust manifold (with integral mounting flange), or on a flange that has been welded to a fabricated manifold. In the case of a welded flange, a minimum flange thickness of 3/8" is recommended to minimize flange warpage. When choosing the location of the wastegate, careful consideration should be taken to insure that the actuator section (top half of wastegate) is NOT exposed to extreme heat. If selected location places the actuator section close to a severe heat source, the use of a heat shield is recommended.
2. Once a suitable mounting location has been selected, determine the routing of the wastegate exhaust. It may exit either away to the side or rear of the vehicle via a dedicated line, or reconnect to the vehicle exhaust system after the turbine housing. **NOTE:** Federal and state laws require that all vehicle exhaust must exit away from the passenger compartment. The exhaust must be connected to the vehicle exhaust system or routed to the outside of the vehicle away from passenger compartment. The **Evolution Wastegate** has designed to be used with 1-1/2" (14-16gauge) tubing, for both inlet and discharge. Be sure to avoid routing any exhaust piping near any fuel or brake lines, or any other heat sensitive components.
3. The **Evolution Wastegate** features the same flange-mount inlet and discharge connections as the Deltagate wastegate (refer to Figure 2). A discharge gasket is supplied with the wastegate kit, and no inlet gasket is required, as the floating valve seat acts as the inlet seal. Be sure all mating surfaces are flat and free of irregularities. Once all mounting and discharge routing provisions have been determined and fabricated, install and secure the wastegate with 5/16" diameter fasteners (grade 5 or better recommended) and mechanical locknuts (conventional lockwashers loose their holding power when exposed to high temps). **NOTE:** A variety of mating flanges, fittings and other accessories are available from your nearest Turbonetics distributor (see common accessories list on last page).
4. Refer to the sensing line schematic shown in Figure 1. A minimum sensing line size of 1/8" ID is recommended for proper response. The wastegate actuator ports are 1/8" NPT pipe thread. Use Teflon tape on all fitting threads. Sensing line material should be suitable for automotive under-hood environment, and compatible with gasoline vapor. Care should be taken in routing sensing lines to avoid damage from any sharp edges or excessive temperatures.
 - **Stand-alone Installation:** If **Evolution Wastegate** is to be installed as a conventional wastegate, the boost sensing line (bottom port) may be connected to any convenient manifold pressure source, such as compressor discharge or intake manifold plenum (plenum runner locations not recommended, as they may cause pulsing which may affect control stability). The top port may be plugged with a filtered vent or connected to the air intake system after the filter.
 - **Variable boost control installation:** If **Evolution Wastegate** is to be used in conjunction with a variable boost control device, follow the manufacturer's instructions relative to connections and routing. As in the conventional wastegate installation, it is strongly recommended that the boost sensing line be connected directly to the pressure signal source (do NOT tee into this line for any other function).
5. The **Evolution Wastegate** has been factory calibrated to control boost within 1psi of the "boost level" decal affixed to the actuator cover (the number refers to the factory installed spring; 5, 7 or 9). Using a suitable manifold pressure gauge, road test the vehicle to ascertain proper operation. If boost levels exceed specified limits during road testing, recheck all sensing line connections for proper location and leaks. Re-test to verify. **CAUTION:** If detonation occurs, discontinue testing until source of detonation has been located and resolved. DO NOT operate vehicle in detonation, as severe engine damage may result. Any damage incurred as a result of improper installation or usage is a customer responsibility.

BOOST ADJUSTMENT: The *Evolution Wastegate* is designed with a “shim” type spring preload adjustment system. To adjust the preload of the installed spring (and therefore the opening pressure of the wastegate), remove top actuator cover by removing the 6 screws (take caution, as the installed spring will be loaded).

- To lower the spring preload, install smaller spring, re-assemble and road test to verify new setting.
- To increase spring preload by a small amount, install 2 or 3 shims between the top spring retainer and the actuator cover (refer to Figure 3), re-assemble and road test to verify new setting.
- To increase spring preload by a larger amount, install larger spring, re-assemble and road test again.

CAUTION: When increasing the preload, adjust in small enough increments to avoid excessive boost and possible detonation (for reference, 2 or 3 shims = approximately 1psi increase in boost).

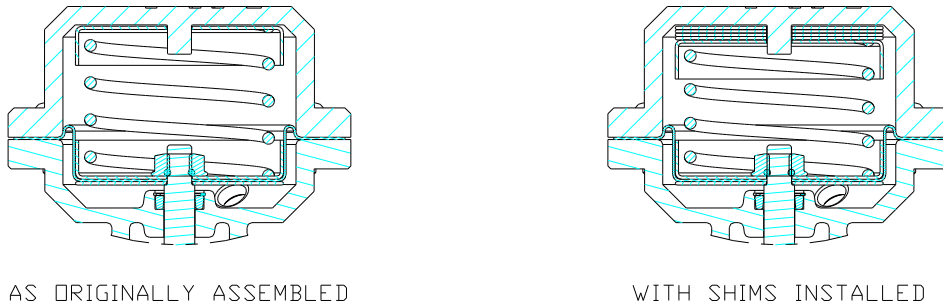

Figure 3:

- Under normal use, the *Evolution Wastegate* requires no maintenance. As a preventative maintenance measure, it is suggested that the vehicle be “exercised” (operated at controlled boost levels) as often as possible to avoid any sticking concerns generated by build-up of deposits on the valve or shaft mechanism. It is also a good idea to periodically check all hose & flange connections for leaks, especially after install.

KIT CONTENTS (part number in bold):

The following items are included in the *Evolution Wastegate* kit - **10780**:

- (1) Main wastegate assembly (one of the springs will be installed)
- (1) 5 PSI spring (blue) – **30778-5**
- (1) 7 PSI spring (white) – **30778-7**
- (1) 9 PSI spring (red) – **30778-9**
- (1) Discharge gasket – **20142**
- (5) Shims – **20643**
- (2) Hose fittings, straight, 1/8 NPT x 5/32 – **30306**
- (2) Hose fittings, elbow, 1/8 NPT x 5/32 – **30307**
- (6ft) Silicone hose (sensing line), 5/32 – **30542**
- (1) Instruction sheet – **60117**

The following items are common accessories used with the *Evolution Wastegate*:

- Mating flange, drilled, steel – **20260**
- Mating flange, drilled, stainless – **20260S**
- Mating flange, tapped, steel – **20261**
- Mating flange, tapped, stainless – **20261S**
- Hose fitting, 3-way tee, 5/32 – **30308**

