



INSTALLATION INSTRUCTIONS
WIS – WATER INJECTION SYSTEM

P/N 30993





READ THIS FIRST: Study these instructions completely before proceeding. Engine and/or turbocharger damage may occur if any component within these instructions is improperly installed. Turbonetics, Inc or any of its distributors cannot be held responsible for damages as a result of negligent or improper installation. This complete water injection system can be installed using common tools and automotive procedures, but installer must have a thorough knowledge of automotive engine operation and feel comfortable working on the vehicle. If in doubt, contact Turbonetics' technical support staff at 805-581-0333, between the hours of 8:00AM and 5:00PM PST, Monday through Friday.

Remove the water injection system from its carton and inspect for any obvious physical damage. All kit components are thoroughly inspected and carefully packaged prior to shipment from the factory. If any shipping damage is evident, contact your supplier and request that they process a claim with the shipper involved. Be sure to review the parts list on page 2 to verify that you have all necessary system components to proceed. If any components in the parts list are missing, contact Turbonetics' customer service staff.

Although this water injection system has been designed to use with many of the factory emissions controls, it is not currently "smog" legal in California, and therefore recommended for "off road" use only. In other states, check local laws regarding aftermarket modification to emission controlled vehicles.

The information contained in this publication was accurate and in effect at the time the publication was approved for printing and is subject to change without notice or liability. Turbonetics reserves the right to revise the information presented herein or to discontinue the production of parts described at any time.

SAFETY REQUIREMENTS: It is recommended to follow these precautions.

- Always wear safety glasses & gloves.
- Turn the ignition switch to the OFF position & disconnect the battery.
- Always use properly rated jack stands when working under the vehicle.
- Prevent unexpected vehicle movement by using wheel chocks and/or parking brake.
- Operate the vehicle only in well ventilated areas.
- Do not smoke or use flammable items near or around the vehicle's fuel system.
- Keep hands, clothing and other objects away from moving parts when engine is running.

SUPPLIES: It is recommended to have the following items before beginning installation.

- A large table or bench, and plenty of adjacent available workspace
- Standard selection of automotive tools, primarily metric sizes
- An assortment of "zip ties" and/or thin-gauge steel wire
- The ability to securely lift the vehicle at least a few feet off the ground
- High temp. automotive RTV sealant
- NPT thread sealant

WATER INJECTION SYSTEM PARTS LIST:

QTY	DESCRIPTION	P/N 30993
1	Pump, Water	X
1	Controller	X
1	Filter	X
1	Water Jet – 1.0mm Orifice	X
106"	Hose, Nylon – 4mm	X
106"	Hose, Nylon – 6mm	X
1	Tap, M8 x 0.75mm	X
1	Fitting, Bulk Head	X
1	Harness, Wiring	X
1	Install Instructions	X

WATER PUMP



BULK HEAD FITTING



WATER JET – 1.0 MM



TAP – M8 x 0.75



FILTER



CONTROLLER



WIRING HARNESS



NYLON HOSE – 4MM



NYLON HOSE – 6MM





INSTALLING THE WATER INJECTION SYSTEM

1. Securely mount the water pump somewhere in the engine compartment that is cool, away from any heat source.
2. Connect the supplied harness to the pump and connect the wires respectively. SEE DIAGRAM 1 & FIGURE 1

DIAGRAM 1

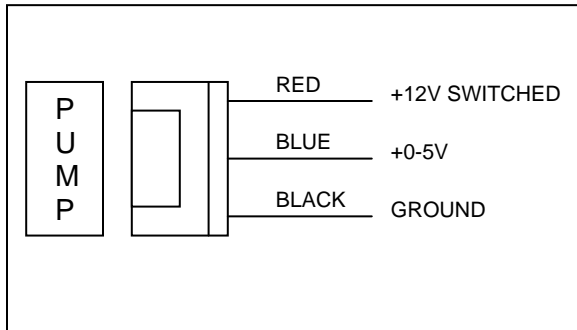
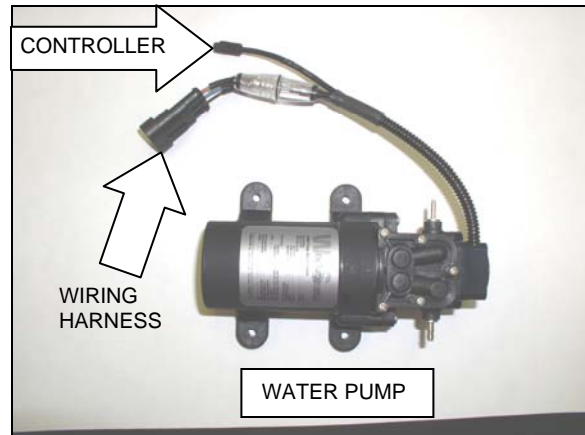
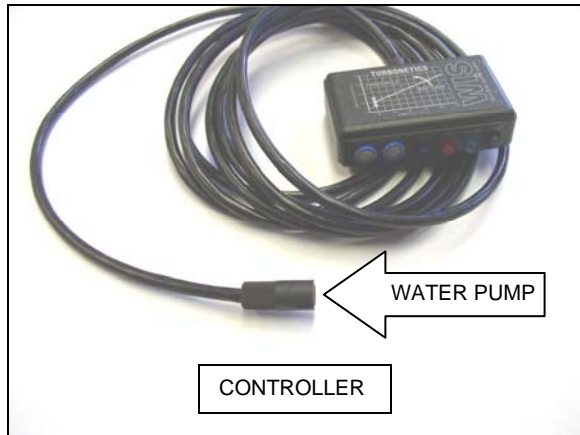

FIGURE 1



3. Mount the controller in the cab using the supplied mounting bracket. Route the harness from the controller to the pump and connect the harness to the pump. SEE FIGURE 2

FIGURE 2



4. If you're using the factory windshield washer reservoir as a water tank, drill a 20mm hole on the bottom of the factory reservoir and install the supplied bulk head fitting. Insert the plastic threaded fitting from the inside of the reservoir, insert the supplied rubber grommet from the outside with the plastic threaded fitting through the center of the grommet, then install the plastic washer, and then secure using the plastic hex nut. Hand tighten. SEE FIGURE 3
5. If you're not using the supplied bulk head fitting in your water reservoir, install the push-in hose fitting to your reservoir.

FIGURE 3

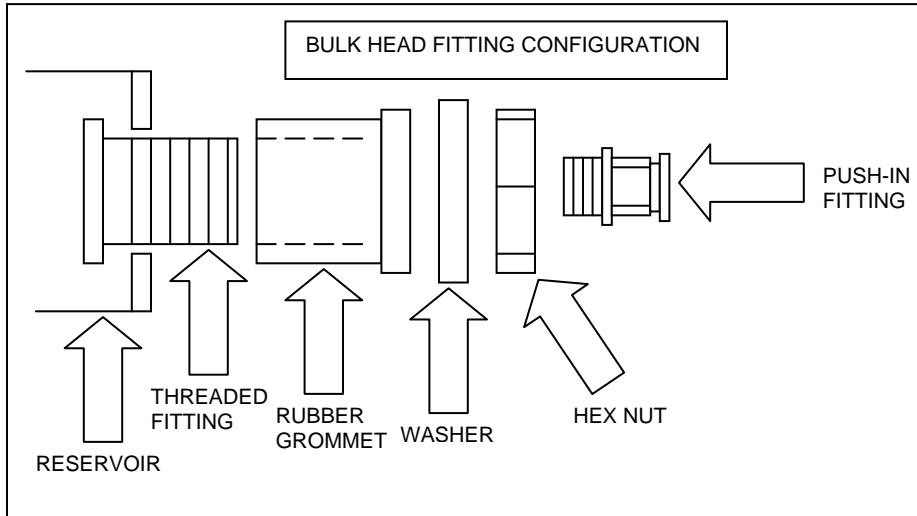

7. Thread the supplied push-in hose fitting into the center of the plastic threaded bulk head fitting. SEE FIGURE 3
8. Use a 7.2mm or 9/32" drill bit, drill a hole in the intake pipe right before the throttle body and thread using the supplied M8x0.75mm tap.
9. Screw the supplied water jet into the threaded hole in the intake pipe.
10. Cut the nylon hose to length. Install the supplied 6mm nylon hose from the water pump to the push-in fitting in the reservoir. Install the supplied 4mm nylon hose from the water pump to the water jet that is installed in the intake pipe.

FIGURE 4

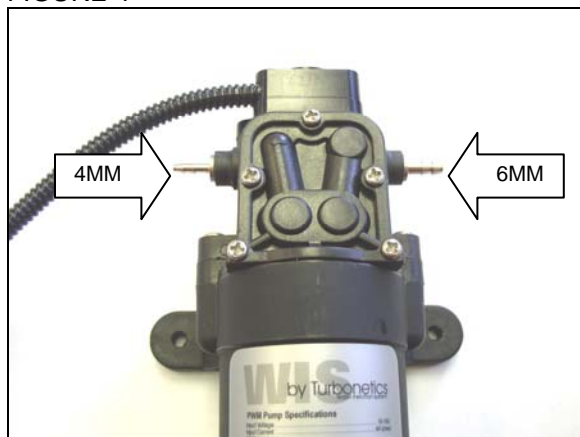

11. Cut the 6mm nylon hose between the pump and the reservoir in half and install the supplied filter. Slide the 6mm nylon hose through the unthreaded side of the white hex nut and into the center of the threaded port of the filter and screw the hex nut to the filter. Do that for both sides and hand tighten. SEE FIGURE 5

FIGURE 5

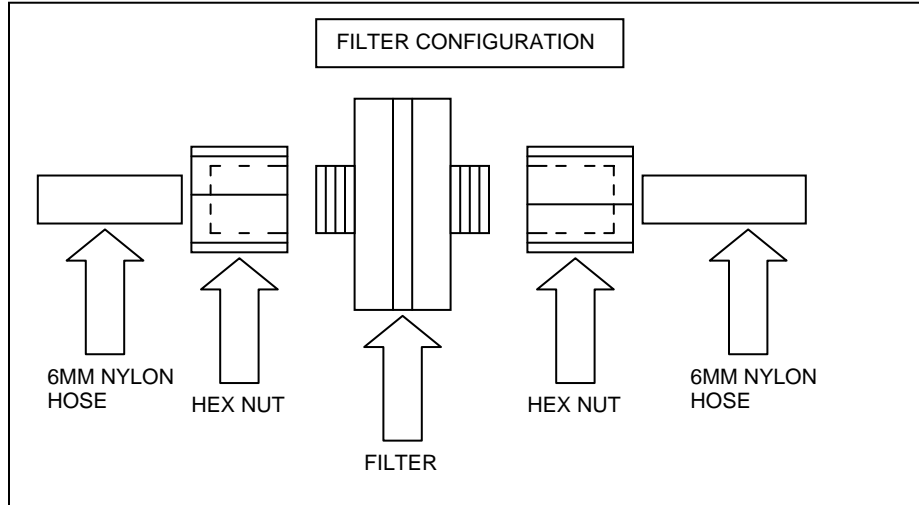

SETTING THE WATER INJECTION SYSTEM

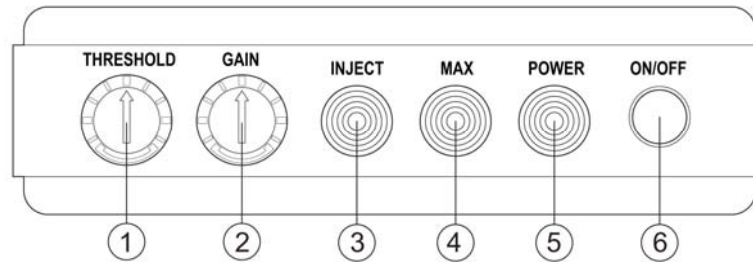

1. THRESHOLD ADJUSTMENT DIAL:

This dial determines the starting point of the water injection system, it has eight indexed positions. The actual point of injection is relative to the sensor used. Most sensors such as MAP (Manifold Absolute Pressure) sensor, MAF (Mass Air Flow) sensor etc has an output voltage of 0-5VDC. The WIS require such a voltage input to start the Water spray. More details on this later.

2. GAIN ADJUSTMENT DIAL:

Once the injection point is determined, we need to set the amount of quantity of liquid relative to the input voltage from the sensors. The "GAIN" dial does such that. In order to make the setting relative simple, the WIS provides two leds to indicate the "START" point and "END" point of the progressive spray range. The "GAIN" dial has a wide gain range so only adjust it with very small increments.

3. INJECT LED (blue):

This LED shows the starting point of the water spray. The brightness of the led will increase as the duty cycle of the water injection pump increases. The WIS sends a PWM (Pulse Width Modulated) signal to control the speed of the water pump. Higher pump speed creates more pressure so mass flow will increase relatively.

4. MAX LED (red):

When the pump speed is approaching 85% of the maximum power, this led will come on and alert the user that the setting of the "GAIN" dial is near this ideal setting. This feature makes the setting up of the WIS system very simple.

4. POWER LED (green):

This led indicates the WIS is switched on.

5. ON/OFF BUTTON:

Toggle press-button switch for tuning the WIS off or on.

The “THRESHOLD” DIAL EXPLAINED:

We have created a chart of the right to show the details of how the dial works with different types of sensors. We have chosen to use a MAP sensor since it has many variations. Since the WIS is designed to read any sensor with an output voltage of 0-5Volts.

There are basically three common variations to a MAP sensor: 1-bar, 2-bar and 3-bar. The 1-bar sensor is normally found on Naturally Aspirated Engines and the 2/3-bar type on Force Induction Engines. The WIS is designed to work on all those.

A vertical line in the middle on the chart crosses three sensor response lines. At the point of intersection, it translates into three values. For the 1-bar MAP sensor, the WI turn-on point is -4psi below the atmospheric and 2/3-bar sensors trigger at 2 and 11 psi respectively.

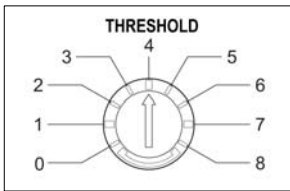

The numbers along the bottom of the chart is same as the numbers indexed on the “THRESHOLD” dial. User can shift the vertical line from the left to the right to arrive at the desired “water spray” onset point by turning the “THRESHOLD” dial.

THRESHOLD vs MAPS

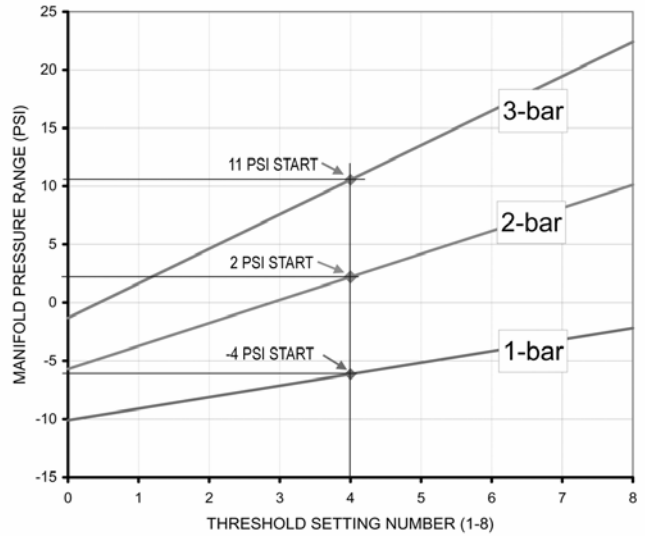

The “GAIN” DIAL EXPLAINED:

In an attempt to accommodate the vast operating range of input signals, the WIS has a huge “electronic input gain adjustment” stage. It is basically shared between eight amplification settings “A” to “I”.

The “A” line on the chart (right) is the least amplified. It starts to increase the pump speed at 1psi (“ON” threshold) ramps the pump speed to 20% at 4psi. If the dial in set to “D”, the pump will reach 95% in the same “4psi” signal. Please note when the “D” line crosses the 85% duty cycle region, the “MAX” led will be lit.

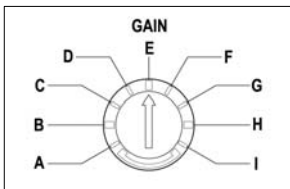

PUMP DUTY CYCLE vs BOOST

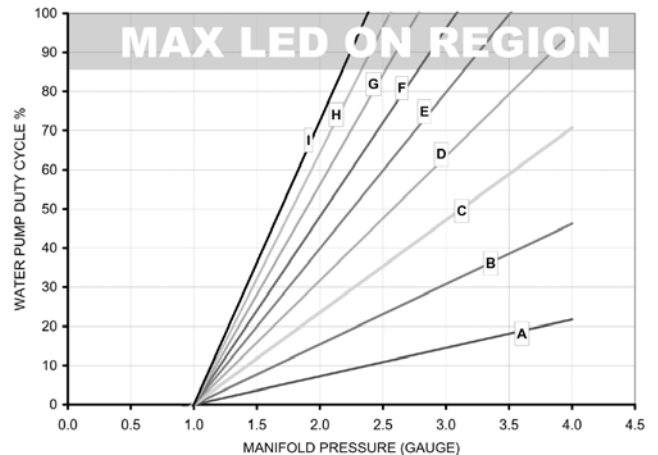



FINAL CHECKLIST:

- Review these instructions to make sure that all fasteners, clamps & electrical connections have been installed & torqued correctly.
- Check that all hose routings are free of any kinks or near any hot or abrasive surfaces, that may cause wear over time. Adjust or reroute as necessary to provide adequate slack for engine movement.
- The use of premium octane unleaded fuel is required for proper engine performance and to reduce the possibility of internal engine damage from detonation.
- Cycle the ignition to the "ON" position several times to pressurize the fuel system & check for any leaks.
- Start the vehicle and check for any oil, power steering or air pressure leaks.

"NO FAULT / NO HASSLE" WARRANTY PROGRAM:

TURBONETICS will repair or replace, at our expense, any new TURBONETICS / Spearco products that fail, including products used in racing or competition applications, for a period of one year from the original date of purchase. All turbocharger and cartridge assemblies have a factory installed inline oil filtration device. This filter device must remain in place if any warranty is to be considered under the No-Fault / No-Hassle program. Electrical components that fail due to misuse are not covered under the No-Fault / No-Hassle Warranty Program.

Warranty is limited to TURBONETICS products and does not include progressive or subsequential damage and does not cover removal or installation labor or associated parts. No warranty is made for any other claims for special, indirect or consequential damages including but not limited to component removal or installation equipment downtime, prospective profits or other economic loss.

Warranty will not be granted for recurring damage, malfunction, or failure due to improper installation, misuse, unauthorized repair or alterations, or externally induced physical damage.

Warranty is non-transferable and must be processed via the original purchaser from TURBONETICS.

Remanufactured units, performance upgraded units, and O.E.M. replacement units are covered by a 90-day warranty or the O.E. warranty period.

TURBONETICS highly recommends that the installation of mechanical or electrical parts be performed by trained professionals. Improperly installed products may lead to unsafe and unreliable conditions.

RETURN POLICY:

Only unused and complete merchandise may be accepted for return subject to inspection and acceptance by TURBONETICS. No goods will be accepted without prior return authorization from TURBONETICS. Call for approval and RGA (Returned Goods Authorization) tracking number. No returns will be accepted without an RGA tracking number. No returns will be accepted after ninety (90) days from the original shipping date from TURBONETICS unless approved. All approved returns are subject to a 15% restocking charge – NO EXCEPTIONS. The original invoice must accompany the return. Accepted warehouse / distributor and open account returns will be issued credit only.

RETURNED GOODS AUTHORIZATION TRACKING NUMBER:

TURBONETICS will only accept product returns, repair orders / upgrades, and warranty requests that have been approved and are returned with a corresponding RGA (Returned Goods Authorization) tracking number.

Contact TURBONETICS for approval and the RGA number. Write the RGA number clearly on the outside of the package and include it inside the package. This is very important in allowing us to properly identify and process your request. Failure to comply with this requirement will result in the delay of processing or the product being returned to you.